



THREE SINHA Retractable Gate

STAINLESS STEEL

RG-SS001



- 3cm heavier chassis calm head
- Sealed anti-friction bearings, plus fortified sand water proof design greatly enhancing service life
- Ø 25 increase the axle to ensure that no deformation
- High strength and durable aluminium rubber wheel test thousands of times back and forth without significant wear
- Windproof design, security gates resist typhoons

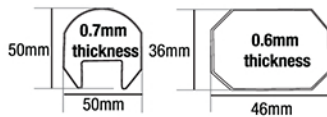

201# and 304# Selectable	
Standard High	: 1.6m (Max. High 2.2m)
Wheels material	: Casting Aluminium Alloy
Middle Cross Tube	: 3XXX
Motor	: Double motor (single motor Selectable)
Rail	: No Need Rail (Need Magnets)
Work Voltage	: AC220V+-10%50Hz
Motor Power	: 350W
Work Temperature	: -35°C~+110°C
Motor Rated Current	: 3.4A
Motor Working System	: S2
Reduction Ratio	: 30:1
Move Speed	: 17m/min
Cooling Fan Power	: DC12V
Relative Humidity	: 95%
Insulation Level	: Level E

Folding Width Per Meter : 0.19 / m
 Motor Unit Width: 0.4m
 Total Area : (X) m
 Effective Width: (X) m - [0.19 x (X)]+0.4mm

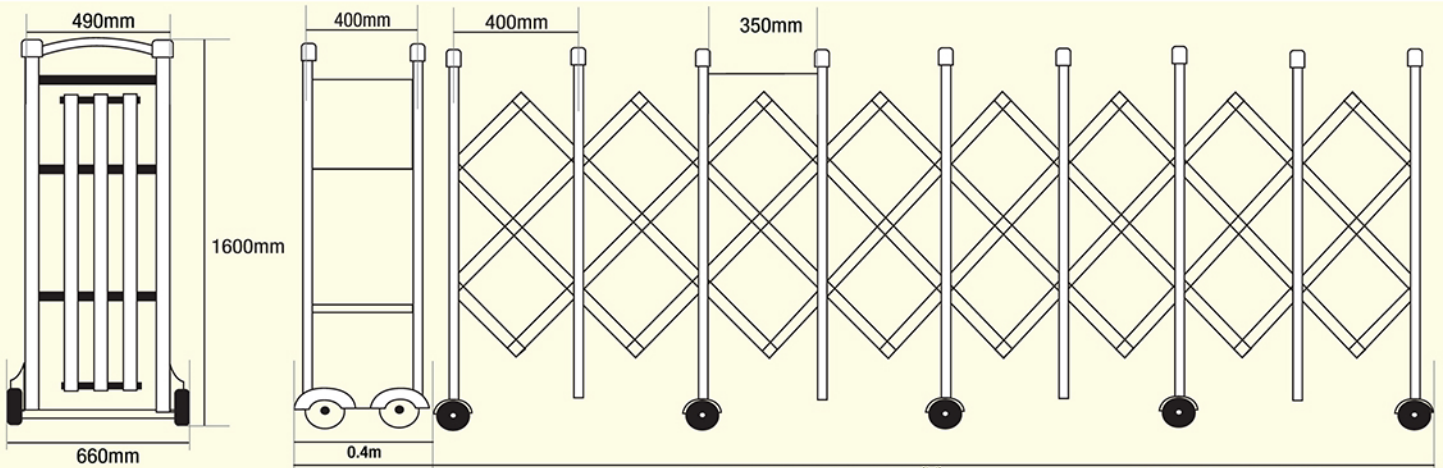

Maximum Length 20 meters (X)

S/S Grade 304 & S/S Grade 301

448, NAWALA ROAD, KOSWATTA, RAJAGIRIYA, SRI LANKA.

Tel: 2 875 356, 2 865 427, 2 883 620, 2 883 621 Hotline: 0117 65 65 65

Fax: 2 863 608(General) 2 078 058 (Marketing)

Email: marketing@threesinha.lk

0768 768 139

0117 65 65 65 www.threesinha.lk



THREE SINHA Retractable Gate

ALUMINIUM

RG-ALU001



Folding Width Per Meter : 0.19 / m
 Motor Unit Width: 0.4m
 Total Area : (X) m
 Effective Width: (X) m - [0.19 x (X)]+0.4mm

Aluminium Alloy
 Standard High
 Wheels material
 Middle Cross Tube
 Motor
 Rail
 Work Voltage
 Motor Power
 Work Temperature

:1.6m (Max. High 2.2m)
 : Casting Aluminium Alloy
 : 3XXX
 : Double motor (single motor Selectable)
 : No Need Rail (Need Magnets)
 : AC220V+-10%50Hz
 : 350W
 :-35°C~+110°C

Motor Rated Current : 3.4A
 Motor Working System : S2
 Reduction Ratio : 30:1
 Moving Speed : 17m/min
 Cooling Fan Power : DC12V
 Relative Humidity : 95%
 Insulation Level : Level E

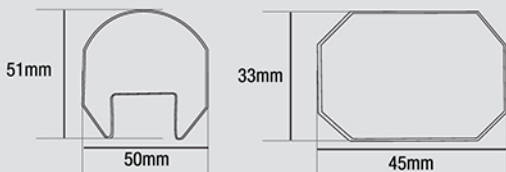
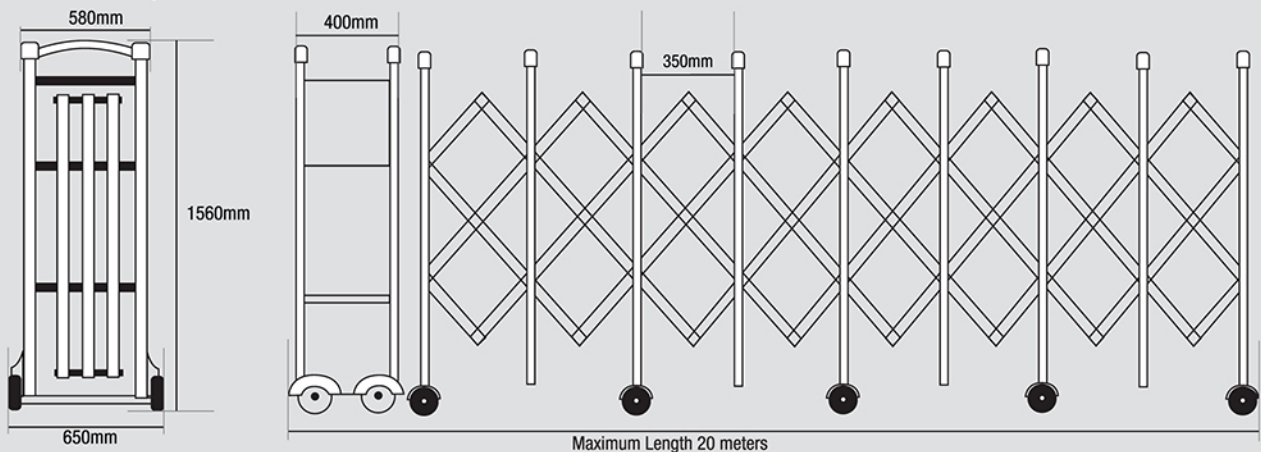

Available Color
**SILVER &
 BLACK**

**Call Us More Info:
 0768 768 139**

448, NAWALA ROAD, KOSWATTA, RAJAGIRIYA, SRI LANKA.
 Tel: 2 875 356, 2 865 427, 2 883 620, 2 883 621 Hotline: 0117 65 65 65
 Fax: 2 863 608(General) 2 078 058 (Marketing) Email: marketing@threesinha.lk

0117 65 65 65
www.threesinha.lk